



## ECD-B SERIES

### ELECTRONIC CONDENSATE DRAIN

**16 bar**  
operating pressure

**15 to 150 l/h**  
drain capacity

**1/2"**  
connections

**1,5 to 65 °C**  
operating temperature range

#### DESCRIPTION

ECD-B series is designed for fully automatic discharging of condensate or any other non-aggressive fluid from compressed air system. For any other technical gas please contact producer or your local distributor.

The units can be installed as external drain on any application specified. Condensate accumulates in the collecting reservoir and when the level is high enough condensate is being discharged from the system without any air losses. Fluid level is detected by precise capacitive level sensor.

Special self-cleaning direct acting valve assures reliable operating. ECD-B series is also equipped with operation alarm, led indicator, test button and internal strainer.

ECD-B series can be used in variety of applications. For applications not listed please contact producer or your local distributor.



#### APPLICATIONS

- Air compressor (piston or screw)
- After-cooler
- Cyclone condensate separator
- Pressure vessel/air tank
- Air filter

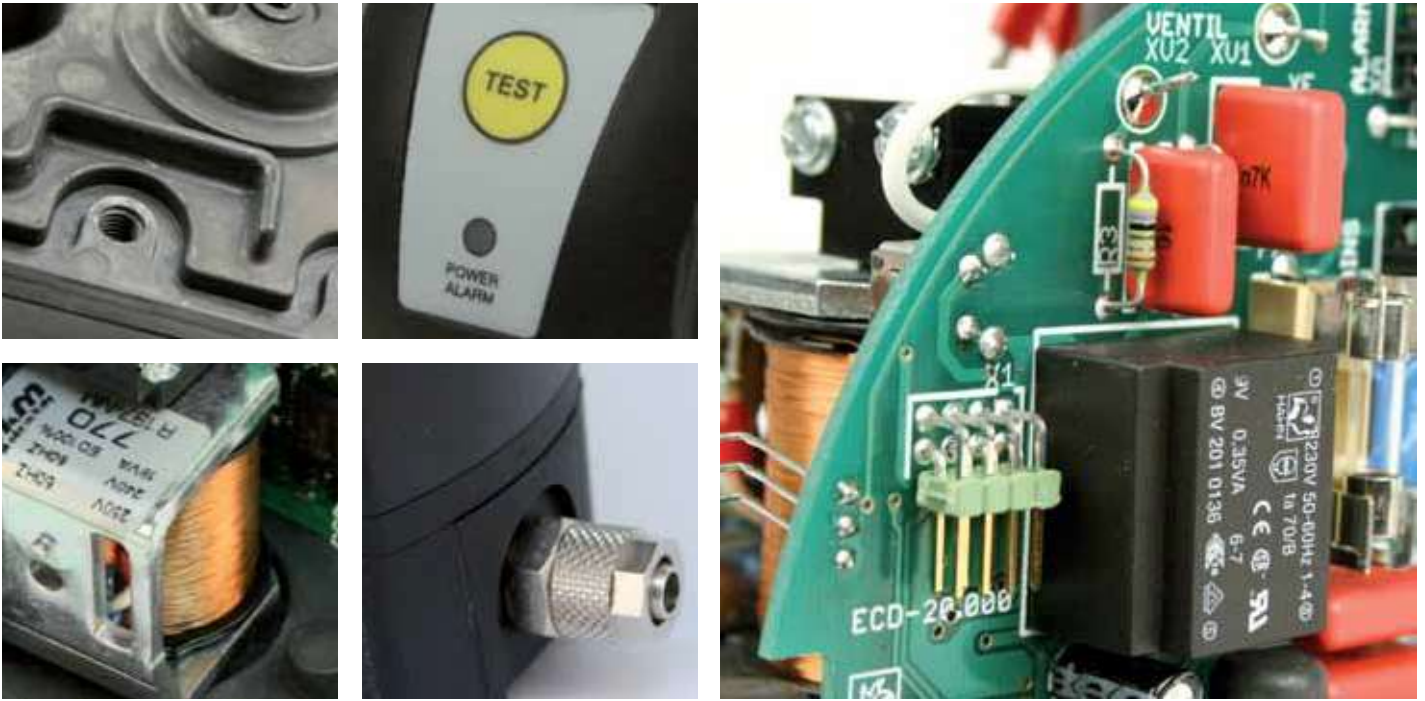

TECHNICAL DATA		ECD 15B	ECD 40B	ECD 90B	ECD 150B
Voltage	115 VAC	115 V ± 10 %	115 V ± 10 %	115 V ± 10 %	115 V ± 10 %
	230 VAC	230 V ± 10 %	230 V ± 10 %	230 V ± 10 %	230 V ± 10 %
Power	115 VAC	24 VA	24 VA	24 VA	24 VA
	230 VAC	24 VA	24 VA	24 VA	24 VA
Frequency	50-60 Hz				
Operating pressure	16 bar (232 psi)				
Drain capacity (at 7 bar/101 psi)	15 l/h (0,0088 cfm)	40 l/h (0,023 cfm)	90 l/h (0,053 cfm)	150 l/h (0,088 cfm)	
Operating temperature range	1,5 - 65 °C (35-149 °F)				
Inlet connection	R 1/2"	R 1/2"	R 1/2"	R 1/2"	
Outlet connection	R 1/8"	R 1/8"	R 1/8"	R 1/8"	
Power interface	3 × 0,75 mm <sup>2</sup>	3 × 0,75 mm <sup>2</sup>	3 × 0,75 mm <sup>2</sup>	3 × 0,75 mm <sup>2</sup>	
Protection class	IP54				
Mass [kg]	0,9	0,9	1,05	1,15	
Dimensions A × B × C [mm]	120 × 82 × 125	120 × 82 × 125	120 × 82 × 135	120 × 82 × 150	
Peak compressor performance [m <sup>3</sup> /min]	a	11,6	29,4	60,6	111,6
	b	9,3	23,5	48,5	89,3
	c	5,8	14,7	30,3	55,8
Peak dryer performance [m <sup>3</sup> /min]	a	23,2	58,8	121,2	223,2
	b	18,6	47,0	97,0	178,6
	c	11,6	29,4	60,6	111,6
Peak filter performance [m <sup>3</sup> /min]	a	116	294	606	1116
	b	93	235	485	893
	c	58	147	303	558
Compressor motor power [kW]	up to 30	up to 75	up to 160	up to 315	

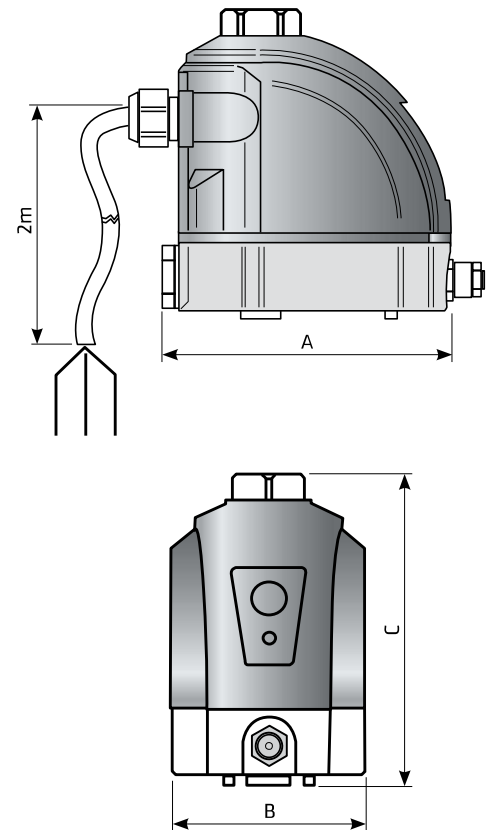

Please take the relevant climate zone into account when dimensioning yours specific ECD-B drain series application:

- a Northern Europe, Canada, Northern USA, Central Asia
- b Central and Southern Europe, Central America
- c South East Asian coastal regions, Oceania, Amazon and Congo regions