

# DryPlus

refrigeration dryers  
from 290 m<sup>3</sup>/min



pure energy

**Purifying your compressed air,  
increasing your efficiency.**



Cooling, conditioning, purifying.

# DRYPLUS



DRYPLUS HAS BEEN DEVELOPED FOR THE MOST DISCERNING USERS, OFFERING ADVANCED TECHNOLOGICAL SOLUTIONS. ENVIRONMENTAL IMPACT IS MINIMIZED, AS IS ENERGY CONSUMPTION. CHOOSE BETWEEN THE LATEST AND MOST ADVANCED COMPRESSOR TECHNOLOGIES. EASE OF USE IS A FURTHER BENEFIT, IN FACT DRYPLUS BOASTS SIGNIFICANTLY SIMPLER START-UP AND MAINTENANCE PROCEDURES THAN TRADITIONAL DRYERS, AS WELL AS ELEVATED RELIABILITY LEVELS. DRYPLUS IS THE OPTIMUM LARGER DRYER SOLUTION.



## CHOOSE BETWEEN THE MOST ADVANCED COMPRESSOR CONFIGURATIONS

### Piston compressors

Semi-hermetic piston compressors are a trusted solution for the industrial User. 3 partialisation steps allow energy savings according to the load to which the dryer is subjected. The semi-hermetic configuration allows maintenance interventions, increasing the working life of the compressor.



### Multiple scroll compressors

Scroll compressors offer 20% energy savings and tolerate liquid refrigerant returns, reducing the chance of compressor damage. Up to 3 compressors switch on and off according to the load, offering excellent energy savings. The 3 compressor configuration also offers added stand-by safety.



### Screw compressors

Screw compressors, widely used in large refrigeration circuits, offer very smooth operation with minimal moving parts, thereby leading to high reliability levels. High efficiency coupled with 3 partialisation steps ensure energy savings are maximized. The simple design requires minimal maintenance.

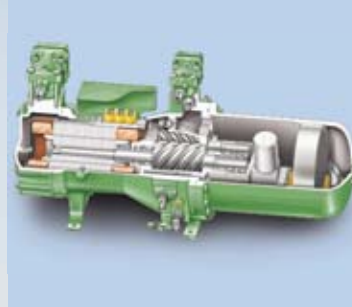

### Centrifugal compressors

An MTA world first, centrifugal compressors offer the most advanced technology. The oil-free design increases efficiency to near isentropic levels and permits the internal inverter to reduce power consumptions down to very low loads. The turbine floats in a magnetic field, reducing friction.

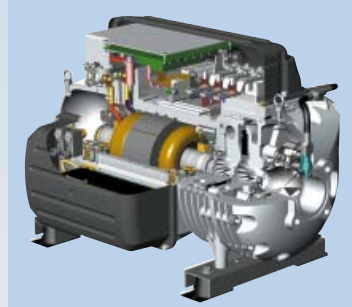



## UNIQUE HEAT EXCHANGER TECHNOLOGY

DryPlus features Direct Expansion technology and is fitted with two heat exchangers, one for the air-to-air section and the other for the evaporator. The benefits are multiple:

**Reduced refrigerant charge** – DryPlus uses a fraction of the refrigerant compared with flooded solutions, for the benefit of the environment.

**Easy to use** - Direct Expansion technology simplifies start-up, and maintenance requirements are notably reduced.

**No oil return difficulties** – DryPlus avoids the oil-return problems suffered by flooded designs.

**Demister pre-filter** – The standard inlet pre-filter means no additional pre-filtration is required, saving capital and installation costs and avoiding the additional pressure drops caused by the pre-filter.

**Multiple flange access** – Both vessels can be accessed from both sides via flanges, offering extended peace of mind.

**Non air-flow dependent separation** – Maximum condensate separation is guaranteed at all air flows, there is no reduction in efficiency at reduced loads as per centrifugal designs. As a result lowest dew points are guaranteed at all times.

**Robust vessel design** – The vessel itself is made of carbon steel, with a special epoxy coating applied to all parts in contact with humid air, ensuring years of trouble free operation in even the harshest conditions. DryPlus is furthermore well suited to oil-free applications.

**Personalization to User needs** – Personalized vessel designs and vessels in stainless steel or other materials are available, as are ASME, SELO and other approvals.

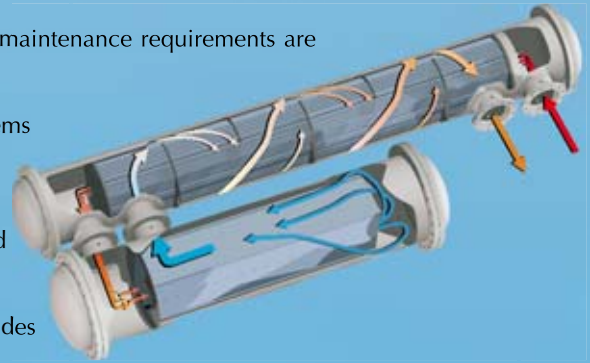

### Advanced microprocessor

DryPlus' microprocessor offers an extensive digital display, full programming and multiple alarms, plus an alarm history which also memorizes dryer operation. RS485 serial connection to MODBUS and other systems is offered, as well as communication via GSM directly to a cell phone.



### zDRAIN (zero-loss drain)

Two zDRAINS (one for each vessel) are fitted, using electronic zero-loss technology to ensure notable energy savings. A sensor in the vessel detects the liquid level, the valve is controlled by the microprocessor. In the event of a fault an alarm is generated and the drain switches to timed operation.



### Environmental

DryPlus requires only a minimal amount of environmentally friendly refrigerant R407C. Energy efficient compressor options with partialisation reduce power consumptions, pressure drops are minimalised, and the zDRAIN avoids unwanted compressed air losses.



### Easy to use & maintain

Unlike flooded dryers, DryPlus is quick and simple to start up. The Direct Expansion design with partialised compressors offers the simplest and most reliable design configuration on the market, ensuring perfect operation at all times with only minimal maintenance needs.



Model	Airflow		Nominal absorbed power (kW)	Condenser water flow (m³/h)	Power supply	Weight (Kg)
	m³/h	m³/min				
BD 290/35	17.400	290	24,2	23,0	400V±10%/3Ph/50Hz	2.850
BD 325/40	19.500	325	28,2	26,5	400V±10%/3Ph/50Hz	3.050
BD 380/50	22.800	380	34,1	30,3	400V±10%/3Ph/50Hz	4.050
BD 450/60	27.000	450	41,9	38,1	400V±10%/3Ph/50Hz	4.480
BD 540/70	32.400	540	50,7	43,4	400V±10%/3Ph/50Hz	4.480

Data refers to version with piston compressor and the following working conditions: air FAD 20°C /1 barA, pressure 7 bar(g), condensing temperature 40°C, air inlet temperature 35°C, pressure dew point 3°C, according to ISO8573.1 standards.

Weights are net (without packing). The refrigerant used is R407C.

Maximum working pressure 10 bar(g), maximum ambient temperature 43°C, maximum inlet temperature 65°C.  
460V±10%/3Ph/60Hz power supply available on request. Condenser water flow refers to 30°C water inlet temperature.

Model	Dimensions (mm)															
	A	B	C	D=E	F	G	N	P	Q	R	S	T	U	V	Z	X
BD 290/35	5036	1813	1971	PN10 - DN250	1.1/4	2.1/2	450	300	500	478	450	560	1682	1797	560	700
BD 325/40	5036	1813	2020	PN10 - DN250	1.1/4	2.1/2	450	300	500	478	450	560	1682	1797	560	700
BD 380/50	5289	1978	2200	PN10 - DN300	1.1/2	3	530	330	600	473	500	558	1784	1900	558	800
BD 450/60	5321	2091	2155	PN10 - DN300	1.1/2	3	530	330	700	473	500	563	1774	1905	558	800
BD 540/70	5371	2298	2185	PN10 - DN350	1.1/2	3	550	350	800	458	600	590	1919	1703	588	800

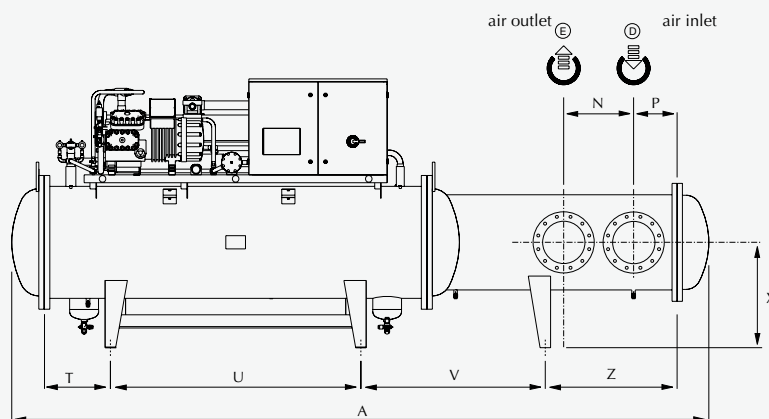
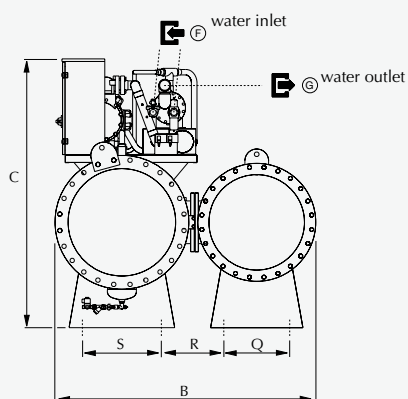

[www.mta-it.com](http://www.mta-it.com)

The data contained herein is not binding. With a view to continuous improvement, MTA reserves the right to make changes without prior notice. Please contact our sales offices for further information. Reproduction in whole or in part is forbidden.



Cooling, conditioning, purifying.



M.T.A. is ISO9001:2000 certified, a sign of its commitment to complete customer satisfaction.



M.T.A. products comply with European safety directives, as recognised by the CE symbol.

**M.T.A. S.p.A.**  
Viale Spagna, 8 - ZI  
35020 Tribano (PD) - Italy  
Tel. +39 049 9588611  
[info@mta-it.com](mailto:info@mta-it.com)

**Compressed air treatment**  
Fax +39 049 9588612

**Process cooling**  
Fax +39 049 9588661

**Air conditioning**  
Fax +39 049 9588604

**Milan branch office**  
Tel. +39 02 95738492

M.T.A. is represented in over 80 countries worldwide. For information concerning your nearest M.T.A. representative please contact M.T.A. S.p.A.

**MTA Australasia**  
Tel. +61 3 9702 4348  
[www.mta-au.com](http://www.mta-au.com)

**MTA China**  
Tel. +86 21 5417 1080  
[www.mta-it.com.cn](http://www.mta-it.com.cn)

**MTA France**  
Tel. +33 04 7249 8989  
[www.mtafrance.fr](http://www.mtafrance.fr)

**MTA Germany**  
Tel. +49 2163 5796-0  
[www.mta.de](http://www.mta.de)

**MTA Romania**  
Tel. +40 368 457 004  
[www.mta-it.ro](http://www.mta-it.ro)

**MTA Spain**  
Tel. +34 938 281 790  
[www.novair-mta.com](http://www.novair-mta.com)

**MTA UK**  
Tel. +44 01702 217878  
[www.mta-uk.co.uk](http://www.mta-uk.co.uk)

**MTA USA**  
Tel. +1 716 693 8651  
[www.mta-it.com](http://www.mta-it.com)